

## technical data sheet // LED spotlight C1-mini-UHC

description:	LED spotlight for installation on magnetic track
housing colour:	aluminium anodised black, silver, brass (other surface finishing on request)
LED type:	high power LED, high CRI
lifetime:	50,000 hours
basis of lifetime:	L70B10
compliant to EMC:	DIN EN 55015:2013
light colour (+/- 100K):	~2700 K, ~3000 K, ~4000 K, ~5700 K
max. luminous flux:	~140 lm
max. power consumption:	~2.3 W
LED driver:	internal
power input:	12V DC constant voltage
dimming:	external
protection class:	IP 20



- recommended accessory: - power supply from series LPF with constant voltage 12V DC, class 2 in combination with a feno dimmer  
- magnetic track (11 x 7 mm), holders
- additional accessory: - lenses: 15°, 18°, 26°, 30°, 45°, 80° and 47°+25°, 40°+10°  
- honeycomb grid, anti-glare tube, inclined tube, snoot, light diffusion foil, barn door

### Dimension

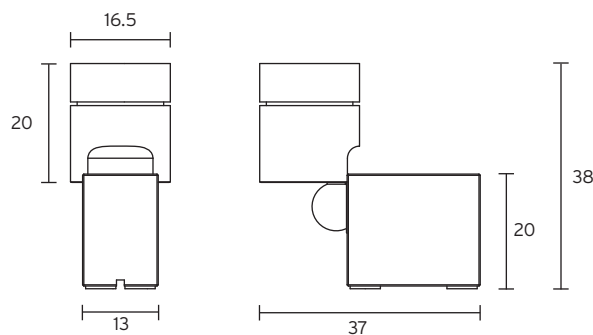

specification in mm

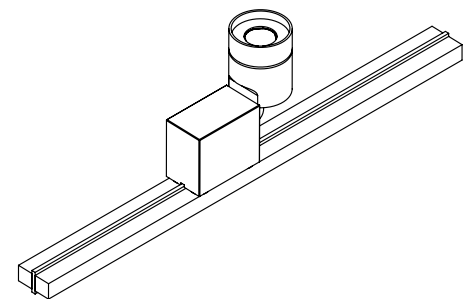

### Test result

for light colour ~3000K // standard lens 30° // colour rendering index typ. 97, R9 > 90, R12 > 90 // colour variation ≤ 3 SDCM

